

General Description

The Rane AD 22d is a fully balanced two Input, two Output audio alignment Delay providing a range of 1.50 to 999.99 milliseconds on each Output. The Delay of each Output is independently adjustable in 10 microsecond and 1 millisecond increments. 24-bit audio converters provide excellent sound quality.

Each Output has two nonvolatile Memories (no batteries required), A and B, for easy access to previously stored Delay values. Remote Recall screw terminals on the rear accept external configuration switches, permitting independent remote recall of the Memories.

The AD 22d features XLR Inputs and Outputs, and is CE certified for emissions. Housed in a single rack space, the unit can operate as two independent channels (dual mono), or as a stereo pair (edit both channels simultaneously).

Delay values can be displayed in milliseconds, feet or meters. The ambient temperature of the room may be manually entered in degrees Celsius or Fahrenheit. This temperature is used to accurately convert distance into time.

A recessed rear panel switch is available for locking out front panel controls. In this mode, all of the front panel pushbuttons are disabled with the exception of the Channel select and Dis-

play Mode buttons. The Channel button remains active so the user may view the Delay values without risk of changing them, and the Display Mode button allows displaying the Delay values in milliseconds, feet or meters. Internal jumpers are available to enable or disable Bypass while in Front Panel Lockout mode. The default setting of these jumpers *disables* Bypass in Front Panel Lockout mode.

Independent bypass relays provide a fail safe, hard-wired bypass in case of power loss.

The AD 22d is a unity gain device with Sensitivity controls to provide proper internal levels for the audio converters. If the input signal is nominally +4 dBu, set the Sensitivity control fully counter clockwise (+4 dBu). For those unable to touch a cable and determine its signal level, Signal present and Clip indicators provide visual acknowledgment that the Input signal is within optimal range.

Powered from a low voltage UL listed and CSA certified remote power supply (230 VAC supply meets LVD 73/23/EEC), the AD 22d is exempt from safety agency requirements, and may be used in any installation mandating agency compliance.

Features

- 1.50 to 999.99 ms Delay Range per Channel
- Two Independent Channels (2 In - 2 Out)
- Independent 10µs and 1ms Step Sizes
- Independent Remote Memory Recall
- Two EEPROM Memories per Channel (No Batteries)
- Front Panel Lockout Switch on Rear
- Delay Display in Milliseconds, Feet or Meters
- Fail-Safe Bypass for Each Channel
- Active Balanced XLR Inputs & Outputs
- UL/CSA/CE and 100/120/230 VAC Remote Power Supplies



Features and Specifications

Parameter	Specification	Limit	Units	Conditions/Comments
Delay Range	1.50 to 999.99	1%	msec	Independently controllable
.....Increment Size	0.01 and 1.00		msec	
.....Readout	5 digit LED			
Propagation Delay	1.50	1%	msec	
Sampling Frequency	50k		Hz	
Data Conversion	24		bit	
Input & Output Connectors	XLR			
Inputs: Type	Active balanced			
.....Impedance	25k	1%	Ω	balanced
.....Headroom	16 above Sensitivity setting	2	dB	20 Hz - 8 kHz
.....Max Level	20		dBu	1 kHz with Sensitivity at +4 dBu
Outputs: Type	Active balanced cross-coupled			
.....Impedance	200	1%	Ω	balanced
.....Max Level	20 (>2k ohm); 18 (>600 ohm)		dBu	1 kHz with Sensitivity at +4 dBu
Overall System Gain	0	±1	dB	
Output Relays	Yes			Auto-bypass with power loss
LED Thresholds: Clip	4 before converter overload	1	dB	1 kHz
.....Signal Present	-34 below Clip LED	1	dB	1 kHz
Frequency Response	20 Hz - 22 kHz	+0/-0.5	dB	+4 dBu, Sens@+4
THD + Noise	0.05	.01	%	+4 dBu, Sens@+4, 20-20k, 30k Hz BW
Signal-to-Noise Ratio	85	2	dB	+4 dBu, Sens@+4, 20 Hz - 20 kHz
Dynamic Range	101	2	dB	+4 dBu, Sens@+4, 20-20k, A-weighted
Crosstalk	>90		dB	20-20 kHz, +4 dBu, Sens @ +4 dBu
Unit: Agency Listing				
.....120 VAC model	Class 2 Equipment UL & CSA			National Electrical Code Exempt Class 2 equipment
.....230 VAC model	Certified FCC Part 15J			Class B Device
Power Supply: Agency Listing				
.....120 VAC model	UL CSA			File no. E88261 File no. LR58948
.....230 VAC model	CE-EMC CE-Safety			EMC directive 89/336/EEC LV directive 73/23/EEC
Power Supply Requirement	18 VAC w/center tap	0.1	Vrms	Rane RS 1
.....Maximum Current	650		mA	RMS current from remote supply
Unit: Construction	All Steel			
.....Size	1.75"H x 19"W x 8.5"D (1U)			(4.4 cm x 48.3 cm x 21.6 cm)
.....Weight	6 lb (w/o power supply)			(2.7 kg)
Shipping: Size	4.25" x 20.3" x 13.75"			(11 cm x 52 cm x 35 cm)
.....Weight	10 lb			(4.5 kg)
<i>Note: 0 dBu=0.775 Vrms</i>				

AD 22d Block Diagram

Channel 1 Shown, Channel 2 Identical

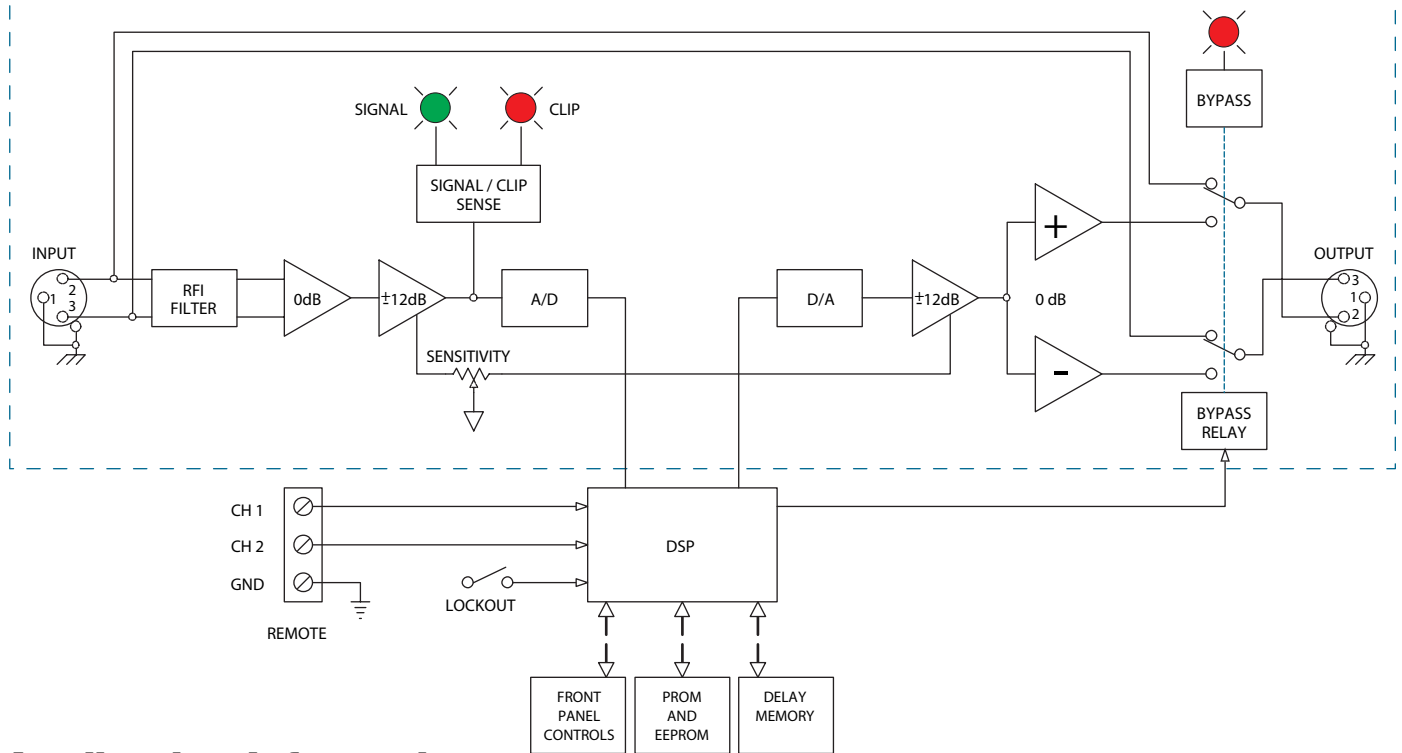

Application Information

SENSITIVITY

To ensure optimal performance, adjust the Sensitivity control so its indicator points to the nominal input signal level. Signal present and Clip indicators provide verification that the signal is within the optimal range. The Sensitivity control adjusts the input and output signal so that the AD 22d is always at unity gain.

SETTING DELAY

There are two modes for setting Delay in the AD 22d: setting one channel at a time and setting *both* channels simultaneously. To set a single channel's Delay, press the Channel button until the LEDs indicate the Channel you want to set (1 or 2). Then press the up/down buttons until the display shows the desired Delay. When editing *both* channels simultaneously (both Channel 1 and 2 LEDs *on*), the display shows the *smaller* of the two current Delay values. In this mode, the two current Delay values are "locked" together. Adjusting the up/down buttons changes both values by the same relative amount. The *edit both mode* allows easy stereo editing and also allows both drivers of a pre-aligned cluster to be moved forward or backward simultaneously.

STORING DELAY

Press the Store button. This stores *both* current Delay values into each channel's current Memory. A channel's current Memory is indicated by the Memory LED lit when editing that channel. The Store LED stops flashing when the current Delay values match the stored values.

RECALLING DELAY

Pressing the Recall button alternately recalls stored Memories (A then B then A...) for the selected channel(s) only.

SETTING TEMPERATURE

Hold down Display Mode and press the up/down buttons to edit the AD 22d's temperature setting. The 1 ms/Coarse buttons display temperature in degrees Celsius, the 10µsec/Fine buttons display degrees in Fahrenheit. No matter which unit (°C or °F), adjustments are always in 1°C steps (or 1.8°F). The AD 22d does not change the current Delay *times* for different temperature settings; *only the displayed distance values are altered.* (See example below.)

REMOTE RECALL

A switch wired to the Remote Recall terminals allows remote recall of stored Memories for each channel. Wire directly to a room divider latch to automatically recall the two room configurations. Or store one Memory with the speaker stack's distance at one temperature and store the other Memory with the stack's distance at another temperature. Then, during the warmer part of the day, restore the warmer temperature.

For example, set up the initial temperature for 71.6°F (the default), and set the stack's distance for 250.00 feet. Press Store to save this value in Memory A (250.00 feet at 71.6°F is 220.85 msec). Then change the temperature setting to 100°F, and we're in Arizona. Notice that the current distance changes to 257.11 feet, but the current Delay *time* is *still* 220.85 msec. Now, edit the current value for 250.00 feet (still your stack's distance). Press Store to save this value in Memory B (250.00 feet at 100°F is 214.74 msec.) Now Memory A has the proper value for the stack at 71.6°F (220.85 msec/250 ft.), and Memory B has the value for 100°F (214.74 msec/250 ft.).

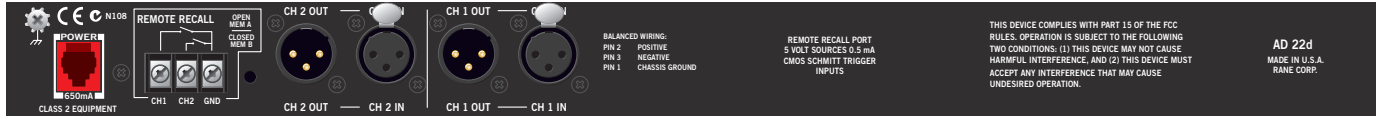
Rear Panel**Architectural Specifications**

The digital audio delay unit shall be a single rack space, two input, two output configuration. The delay adjustment range shall be from 1.50 to 999.99 ms, adjustable via increment/decrement pushbuttons, in both 10 microsecond and 1 millisecond intervals. Independent remote recall terminals shall be provided for external recall of stored configuration memories, two per channel. A five (5) digit LED display shall indicate delay values in milliseconds, feet or meters as well as temperature setting and software revision level. Bypass status, current memory, channel, and display modes shall be indicated with individual indicators.

A recessed rear-panel switch shall disable the front panel, yet still allow viewing of delay values.

Independent input-output sensitivity controls shall be included to allow calibration of the input signal for maximum

performance. The inputs and outputs shall be active balanced with XLR connectors. Each channel shall have indicators for signal present and input/output clip conditions.

The unit shall provide independent, fail-safe bypass relays requiring no power to engage. RFI filters shall also be provided.

The unit shall have certified compliance with FCC docket 20780 Part 15J for Class B computing devices. The AD 22d shall comply with EMCD 89/336/EEC (CE approved). The 120 VAC model shall be powered from a UL listed, CSA certified remote power supply, and the 230 VAC model shall be powered from a remote power supply meeting LVD 73/23/EEC and EMCD 89/336/EEC standards. The unit shall be constructed entirely from cold-rolled steel.

The unit shall be a Rane Corporation AD 22d.

References

1. Shaw, N. "Digital Delays, Parts One, Two & Three," *Sound & Communications*, vol. 39, nos. 3, 5 & 10, (March, May, & October 1993).
2. Bohn, D. "Environmental Effects on the Speed of Sound," *J. Audio Eng. Soc.*, vol. 36, pp. 223-231 (April 1988).